

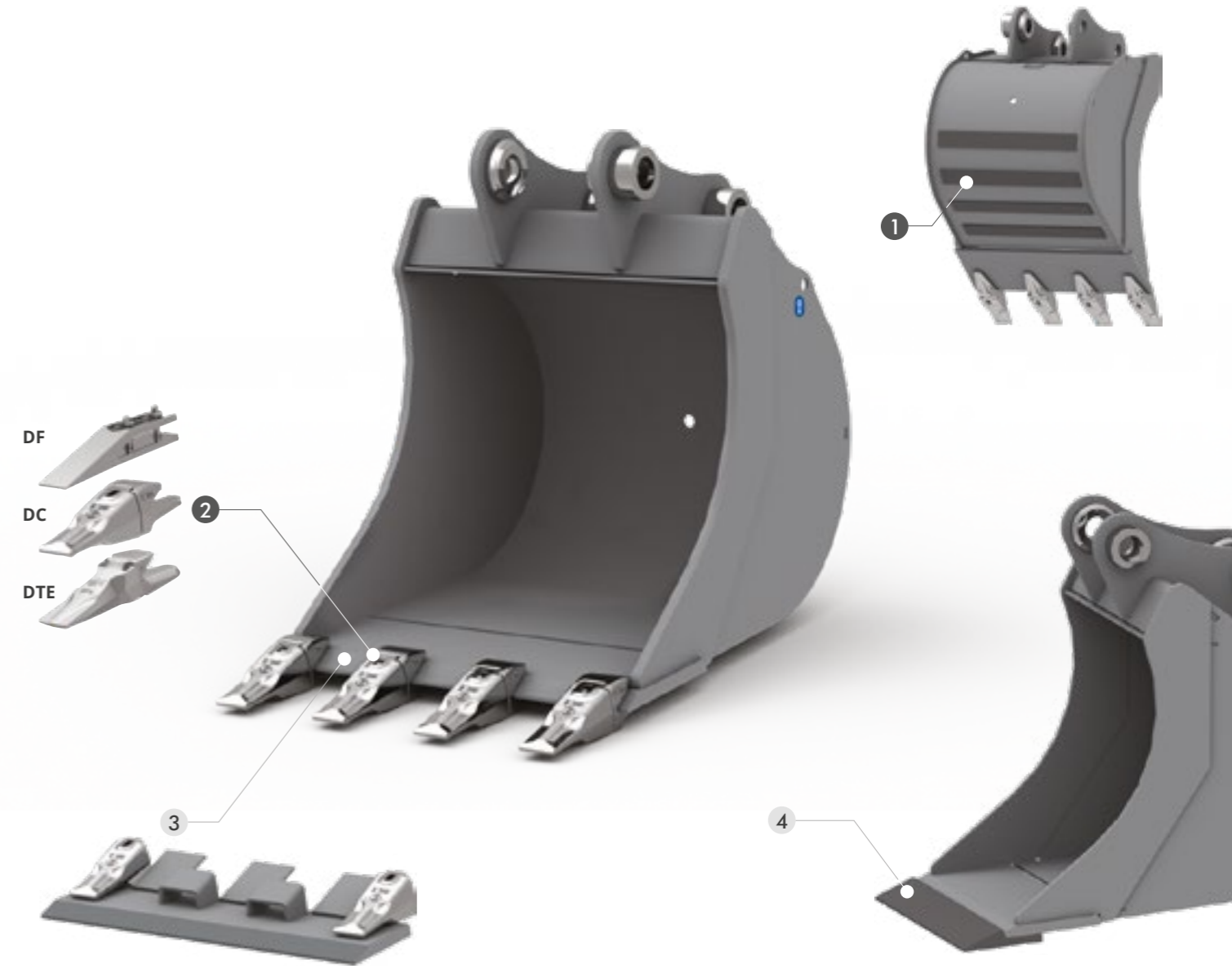

ITS SHAPE HAS BEEN CONCEIVED TO HELP THE TOOL TO PENETRATE MEDIUM-CONSISTENCY SOILS.



STANDARD TECHNICAL FEATURES

- 1 REINFORCING STRIPS**
THE HORIZONTAL REINFORCING STRIPS ON THE BUCKET'S REAR AND BOTTOM PROTECT THE BUCKET FROM WEAR AND INCREASE ITS RESISTANCE.
- 2 DF TEETH DC TEETH DTE TEETH**

OPTIONAL

- 3 GRADING EDGE**
INSTALLED DIRECTLY ON THE ADAPTERS OF THE WELDED TEETH. THIS PATTERN MAKES THE INSTALLING/UNINSTALLING OPERATIONS EASIER AND GRANTS A HIGH RESISTANCE TO THE BUCKET.
- 4 HB500 WELDED ADDITIONAL CUTTING EDGE (NO TEETH)**
RECOMMENDED TO WORK ON PARTICULARLY ABRASIVE SOILS.

MOD.	MIDI EXCAVATOR										SC100GD	SC110GD	
	SC27	SC36	SC38	SC45	SC53	SC62	SC67	SC73	SC80	SC85			
TONS (LB)	0,6 - 1,2 (1323 - 2646)	1,2 - 1,8 (2646 - 3968)	1,2 - 1,8 (2646 - 3968)	1,8 - 2,5 (3968 - 5512)	2,5 - 4,0 (5512 - 8818)	4,0 - 5,0 (8818 - 11023)	5,0 - 7,5 (11023 - 16535)	7,5 - 10,0 (16535 - 22046)	10,0 - 12,0 (22046 - 26455)	12,0 - 14,0 (26455 - 30865)	12,0 - 14,0 (26455 - 30865)	14,0 - 18,0 (30865 - 39683)	18,0 - 22,0 (39683 - 48502)

SC27 MACHINE WEIGHT 0,6 - 1,2 t (1323 - 2646 lb)

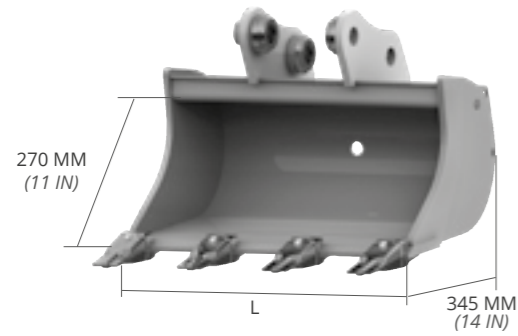

L MM (IN)	WEIGHT KG* (LB*)	CAP. SAE L (GAL)	TEETH N°	ADAPTERS
200 (8)	11 (24)	10 (2,6)	2	AF CM CW
250 (10)	13 (29)	14 (3,7)	DF2 DC3 DE3	AF CM CW
300 (12)	15 (33)	18 (4,8)	3	AF CM CW
350 (14)	17 (37)	21 (5,5)	3	AF CM CW
400 (16)	18 (40)	25 (6,6)	3	AF CM CW
450 (18)	20 (44)	30 (7,9)	3	AF CM CW
500 (20)	22 (49)	34 (9,0)	4	AF CM CW
600 (24)	26 (57)	42 (11,1)	4	AF CM CW
700 (28)	30 (66)	50 (13,2)	5	AF CM CW

* weight of the tank excluding attachment

SC27 QUICK COUPLER MACHINE WEIGHT 0,6 - 1,2 t (1323 - 2646 lb)

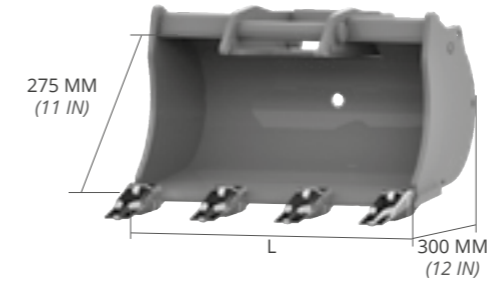
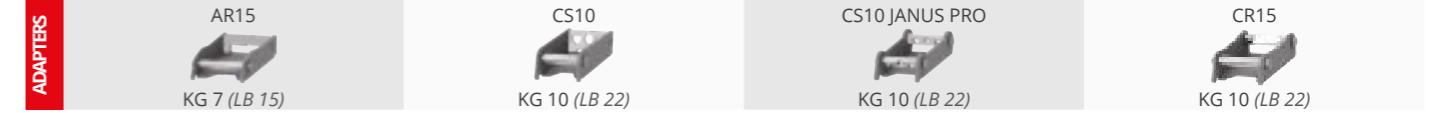

L MM (IN)	WEIGHT KG* (LB*)	CAP. SAE L (GAL)	TEETH N°	ADAPTERS
200 (8)	11 (24)	10 (2,6)	2	AR - CS CR CS JANUS PRO
250 (10)	13 (29)	14 (3,7)	DF2 DC3 DE3	AR - CS CR CS JANUS PRO
300 (12)	15 (33)	18 (4,8)	3	AR - CS CR CS JANUS PRO
350 (14)	17 (37)	21 (5,5)	3	AR - CS CR CS JANUS PRO
400 (16)	18 (40)	25 (6,6)	3	AR - CS CR CS JANUS PRO
450 (18)	20 (44)	30 (7,9)	3	AR - CS CR CS JANUS PRO
500 (20)	22 (49)	34 (9,0)	4	AR - CS CR CS JANUS PRO
600 (24)	26 (57)	42 (11,1)	4	AR - CS CR CS JANUS PRO
700 (28)	30 (66)	50 (13,2)	5	AR - CS CR CS JANUS PRO

* weight of the tank excluding attachment

OPTIONAL

3	4
SUPPLEMENTARY BLADE	HB500 WELDED ADDITIONAL CUTTING EDGE

OPTIONAL

3	4
SUPPLEMENTARY BLADE	HB500 WELDED ADDITIONAL CUTTING EDGE

SC36 MACHINE WEIGHT 1,2 - 1,8 t (2646 - 3968 lb)

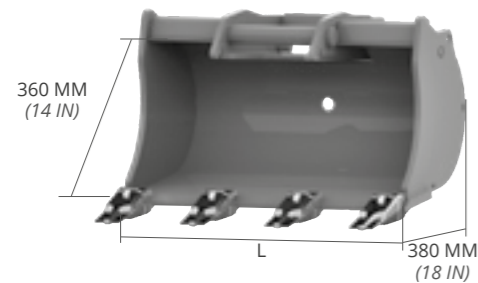
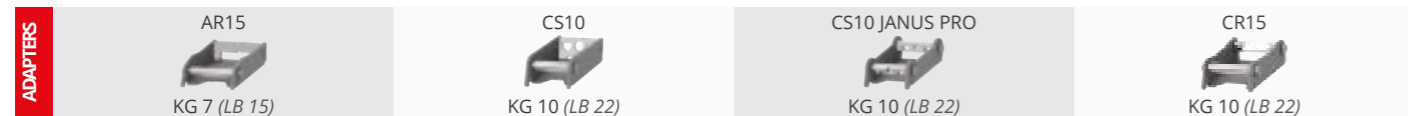

L MM (IN)	WEIGHT KG* (LB*)	CAP. SAE L (GAL)	TEETH N.	ADAPTERS
200 (8)	15 (33)	15 (4,0)	2	AR - CS CR CS JANUS PRO
250 (10)	17 (37)	20 (5,3)	DF2 DC3 DE3	AR - CS CR CS JANUS PRO
300 (12)	19 (42)	25 (6,6)	3	AR - CS CR CS JANUS PRO
350 (14)	21 (46)	31 (8,2)	3	AR - CS CR CS JANUS PRO
400 (16)	24 (53)	37 (9,8)	3	AR - CS CR CS JANUS PRO
450 (18)	27 (60)	43 (11,4)	3	AR - CS CR CS JANUS PRO
500 (20)	30 (66)	49 (12,4)	4	AR - CS CR CS JANUS PRO
600 (24)	34 (75)	61 (16,1)	4	AR - CS CR CS JANUS PRO
700 (28)	39 (86)	74 (19,5)	5	AR - CS CR CS JANUS PRO

* weight of the tank excluding attachment

SC38 MACHINE WEIGHT 1,2 - 1,8 t (2646 - 3968 lb)

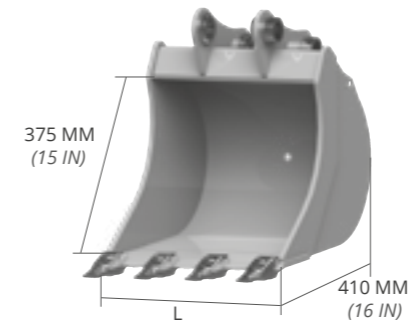
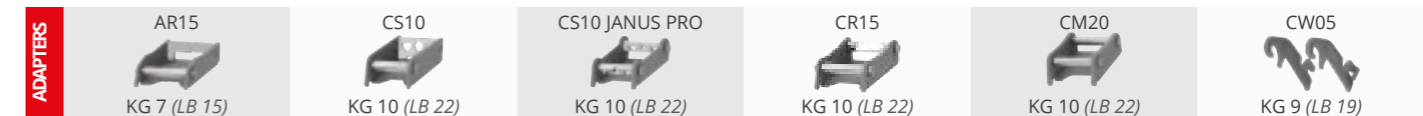

L MM (IN)	WEIGHT KG* (LB*)	CAP. SAE L (GAL)	TEETH N.	ADAPTERS
200 (8)	15 (33)	15 (4,0)	2	AF - AR - CS CR - CM CW - CS JANUS PRO
250 (10)	17 (37)	20 (5,3)	DF2 DC3 DE3	AF - AR - CS CR - CM CW - CS JANUS PRO
300 (12)	19 (42)	25 (6,6)	3	AF - AR - CS CR - CM CW - CS JANUS PRO
350 (14)	21 (46)	31 (8,2)	3	AF - AR - CS CR - CM CW - CS JANUS PRO
400 (16)	24 (53)	37 (9,8)	3	AF - AR - CS CR - CM CW - CS JANUS PRO
450 (18)	27 (60)	43 (11,4)	3	AF - AR - CS CR - CM CW - CS JANUS PRO
500 (20)	30 (66)	49 (12,4)	4	AF - AR - CS CR - CM CW - CS JANUS PRO
600 (24)	34 (75)	61 (16,1)	4	AF - AR - CS CR - CM CW - CS JANUS PRO
700 (28)	39 (86)	74 (19,5)	5	AF - AR - CS CR - CM CW - CS JANUS PRO

* weight of the tank excluding attachment

OPTIONAL

- 3 SUPPLEMENTARY BLADE
- 4 HB500 WELDED ADDITIONAL CUTTING EDGE

OPTIONAL

- 3 SUPPLEMENTARY BLADE
- 4 HB500 WELDED ADDITIONAL CUTTING EDGE

SC45 MACHINE WEIGHT 1,8 - 2,5 t (3968 - 5512 lb)

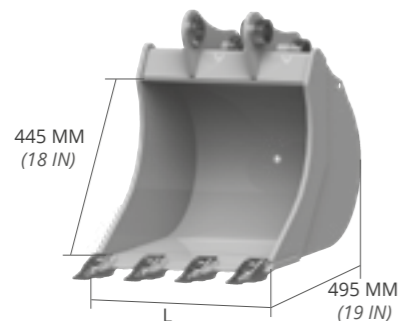

L MM (IN)	WEIGHT KG* (LB*)	CAP. SAE L (GAL)	TEETH N.	ADAPTERS
250 (10)	23 (51)	25 (6,6)	2	AF - AR - CS CR - CM CW - CS JANUS PRO
300 (12)	26 (57)	33 (8,7)	3	AF - AR - CS CR - CM CW - CS JANUS PRO
350 (14)	29 (64)	40 (10,6)	3	AF - AR - CS CR - CM CW - CS JANUS PRO
400 (16)	32 (71)	48 (12,7)	3	AF - AR - CS CR - CM CW - CS JANUS PRO
450 (18)	35 (77)	56 (14,8)	3	AF - AR - CS CR - CM CW - CS JANUS PRO
500 (20)	38 (84)	65 (17,2)	4	AF - AR - CS CR - CM CW - CS JANUS PRO
600 (24)	44 (97)	82 (21,7)	4	AF - AR - CS CR - CM CW - CS JANUS PRO
700 (28)	50 (110)	100 (26,4)	5	AF - AR - CS CR - CM CW - CS JANUS PRO
800 (31)	58 (128)	117 (30,9)	5	AF - AR - CS CR - CM CW - CS JANUS PRO

* weight of the tank excluding attachment

SC53 MACHINE WEIGHT 2,5 - 4,0 t (5512 - 8818 lb)

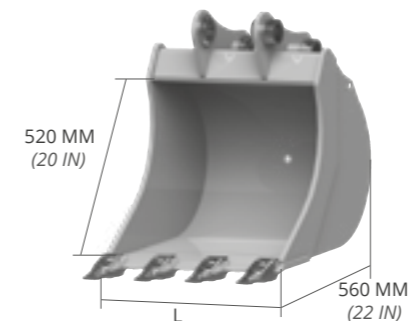
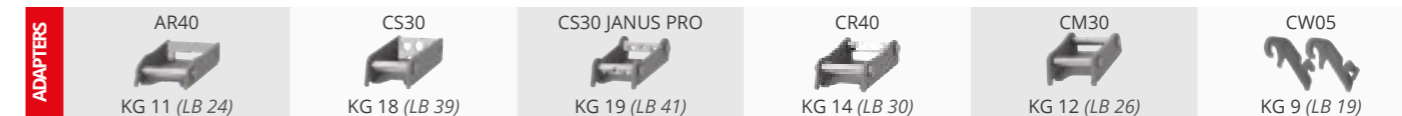

L MM (IN)	WEIGHT KG* (LB*)	CAP. SAE L (GAL)	TEETH N.	ADAPTERS
250 (10)	32 (71)	32 (8,5)	2	AF - AR - CS CR - CM CW - CS JANUS PRO
300 (12)	35 (77)	41 (10,8)	3	AF - AR - CS CR - CM CW - CS JANUS PRO
350 (14)	40 (88)	51 (13,5)	3	AF - AR - CS CR - CM CW - CS JANUS PRO
400 (16)	44 (97)	61 (16,1)	3	AF - AR - CS CR - CM CW - CS JANUS PRO
450 (18)	48 (106)	72 (19,0)	3	AF - AR - CS CR - CM CW - CS JANUS PRO
500 (20)	51 (112)	82 (21,7)	4	AF - AR - CS CR - CM CW - CS JANUS PRO
600 (24)	59 (130)	105 (27,7)	4	AF - AR - CS CR - CM CW - CS JANUS PRO
700 (28)	67 (148)	127 (33,5)	5	AF - AR - CS CR - CM CW - CS JANUS PRO
800 (31)	75 (165)	152 (40,2)	5	AF - AR - CS CR - CM CW - CS JANUS PRO
900 (35)	83 (183)	175 (46,2)	5	AF - AR - CS CR - CM CW - CS JANUS PRO

* weight of the tank excluding attachment

OPTIONAL

- 3 SUPPLEMENTARY BLADE
- 4 HB500 WELDED ADDITIONAL CUTTING EDGE

OPTIONAL

- 3 SUPPLEMENTARY BLADE
- 4 HB500 WELDED ADDITIONAL CUTTING EDGE

SC62 MACHINE WEIGHT 4,0 - 5,0 t (8818 - 11023 lb)

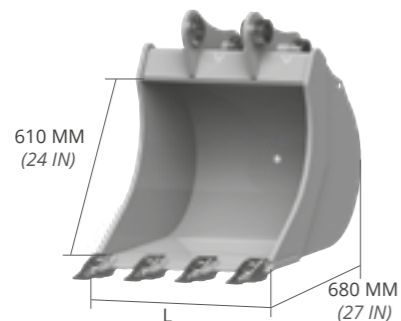
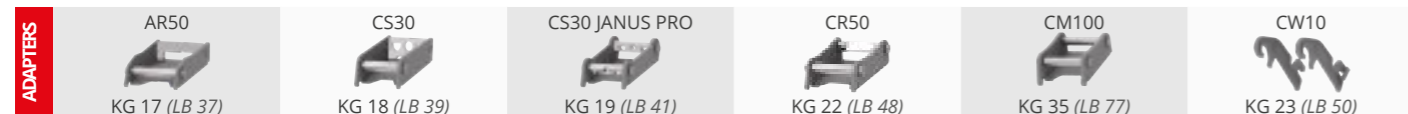

L MM (IN)	WEIGHT KG* (LB*)	CAP. SAE L (GAL)	TEETH N.	ADAPTERS
250 (10)	48 (106)	45 (11,9)	2	AF - AR - CS CR - CM CW - CS JANUS PRO
300 (12)	53 (117)	58 (15,3)	3	AF - AR - CS CR - CM CW - CS JANUS PRO
350 (14)	58 (128)	71 (18,8)	3	AF - AR - CS CR - CM CW - CS JANUS PRO
400 (16)	63 (139)	85 (22,5)	3	AF - AR - CS CR - CM CW - CS JANUS PRO
450 (18)	68 (150)	100 (26,4)	3	AF - AR - CS CR - CM CW - CS JANUS PRO
500 (20)	73 (161)	115 (30,4)	4	AF - AR - CS CR - CM CW - CS JANUS PRO
600 (24)	84 (185)	147 (38,8)	4	AF - AR - CS CR - CM CW - CS JANUS PRO
700 (28)	95 (209)	180 (47,6)	5	AF - AR - CS CR - CM CW - CS JANUS PRO
800 (31)	106 (234)	213 (56,3)	5	AF - AR - CS CR - CM CW - CS JANUS PRO
900 (35)	117 (258)	248 (65,5)	6	AF - AR - CS CR - CM CW - CS JANUS PRO
1000 (39)	128 (282)	282 (74,5)	6	AF - AR - CS CR - CM CW - CS JANUS PRO

* weight of the tank excluding attachment

SC67 MACHINE WEIGHT 5,0 - 7,5 t (11023 - 16535 lb)

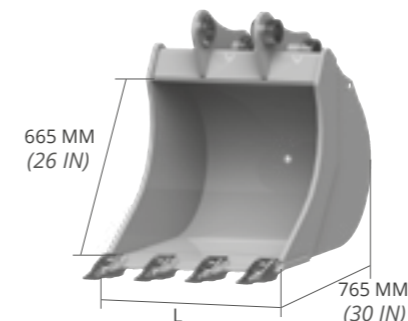
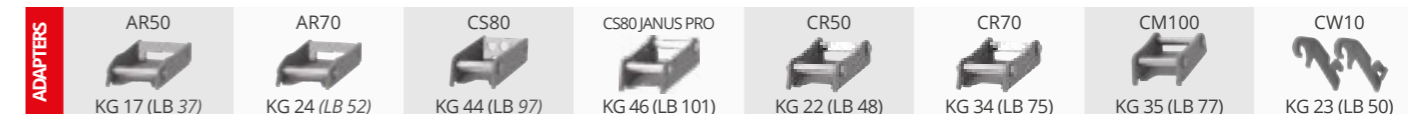

L MM (IN)	WEIGHT KG* (LB*)	CAP. SAE L (GAL)	TEETH N.	ADAPTERS
300 (12)	70 (154)	68 (18,0)	3	AF - AR - CS CR - CM CW - CS JANUS PRO
350 (14)	78 (172)	84 (22,2)	3	AF - AR - CS CR - CM CW - CS JANUS PRO
400 (16)	85 (187)	101 (26,7)	3	AF - AR - CS CR - CM CW - CS JANUS PRO
450 (18)	92 (203)	118 (31,2)	3	AF - AR - CS CR - CM CW - CS JANUS PRO
500 (20)	99 (218)	137 (36,2)	4	AF - AR - CS CR - CM CW - CS JANUS PRO
600 (24)	114 (251)	174 (46,0)	4	AF - AR - CS CR - CM CW - CS JANUS PRO
700 (28)	128 (282)	214 (56,5)	5	AF - AR - CS CR - CM CW - CS JANUS PRO
800 (31)	142 (313)	254 (67,1)	5	AF - AR - CS CR - CM CW - CS JANUS PRO
900 (35)	156 (344)	295 (77,9)	6	AF - AR - CS CR - CM CW - CS JANUS PRO
1000 (39)	170 (375)	338 (89,3)	6	AF - AR - CS CR - CM CW - CS JANUS PRO

* weight of the tank excluding attachment

OPTIONAL

- 3 SUPPLEMENTARY BLADE
- 4 HB500 WELDED ADDITIONAL CUTTING EDGE

OPTIONAL

- 3 SUPPLEMENTARY BLADE
- 4 HB500 WELDED ADDITIONAL CUTTING EDGE

SC73 MACHINE WEIGHT 7,5 - 10,0 t (116535 - 22046 lb)

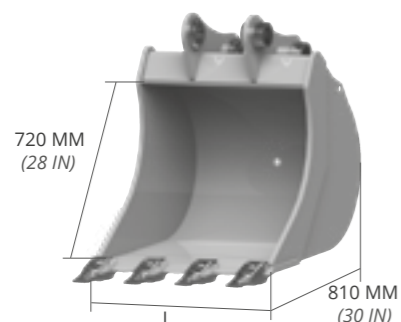

L MM (IN)	WEIGHT KG* (LB*)	CAP. SAE L (GAL)	TEETH N.	ADAPTERS
300 (12)	82 (181)	76 (20,1)	2	AF - CS
				CR - CM
				CW - CS JANUS PRO
350 (14)	89 (196)	94 (24,8)	3	AF - CS
				CR - CM
				CW - CS JANUS PRO
400 (16)	94 (207)	113 (29,9)	3	AF - CS
				CR - CM
				CW - CS JANUS PRO
450 (18)	103 (227)	133 (35,1)	3	AF - CS
				CR - CM
				CW - CS JANUS PRO
500 (20)	111 (245)	153 (40,4)	3	AF - CS
				CR - CM
				CW - CS JANUS PRO
600 (24)	127 (280)	196 (51,8)	4	AF - CS
				CR - CM
				CW - CS JANUS PRO
700 (28)	143 (315)	240 (63,4)	4	AF - CS
				CR - CM
				CW - CS JANUS PRO
800 (31)	159 (351)	286 (75,6)	5	AF - CS
				CR - CM
				CW - CS JANUS PRO
900 (35)	175 (386)	333 (88,0)	5	AF - CS
				CR - CM
				CW - CS JANUS PRO
1000 (39)	191 (421)	379 (100,1)	5	AF - CS
				CR - CM
				CW - CS JANUS PRO
1100 (43)	207 (456)	430 (113,6)	5	AF - CS
				CR - CM
				CW - CS JANUS PRO

* weight of the tank excluding attachment

SC80 MACHINE WEIGHT 10,0 - 12,0 t (22046 - 26455 lb)

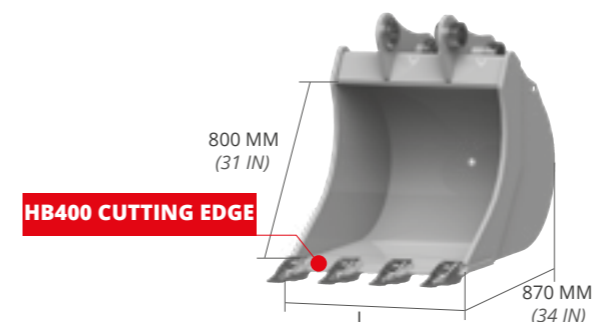

OPTIONAL	
3	4
SUPPLEMENTARY BLADE	HB500 WELDED ADDITIONAL CUTTING EDGE

L MM (IN)	WEIGHT KG* (LB*)	CAP. SAE L (GAL)	TEETH N.	ADAPTERS
300 (12)	102 (225)	86 (22,7)	2	AF - CS
				CR - CM - CS JANUS PRO
				CW
350 (14)	110 (243)	107 (28,3)	3	AF - CS
				CR - CM - CS JANUS PRO
				CW
400 (16)	121 (267)	129 (34,1)	3	AF - CS
				CR - CM - CS JANUS PRO
				CW
450 (18)	130 (287)	151 (39,9)	3	AF - CS
				CR - CM - CS JANUS PRO
				CW
500 (20)	139 (306)	174 (46,0)	3	AF - CS
				CR - CM - CS JANUS PRO
				CW
600 (24)	157 (346)	222 (58,6)	4	AF - CS
				CR - CM - CS JANUS PRO
				CW
700 (28)	175 (386)	273 (72,1)	4	AF - CS
				CR - CM - CS JANUS PRO
				CW
800 (31)	191 (421)	325 (85,9)	5	AF - CS
				CR - CM - CS JANUS PRO
				CW
900 (35)	209 (461)	379 (100,1)	5	AF - CS
				CR - CM - CS JANUS PRO
				CW
1000 (39)	226 (498)	433 (114,4)	5	AF - CS
				CR - CM - CS JANUS PRO
				CW
1100 (43)	244 (538)	486 (128,4)	5	AF - CS
				CR - CM - CS JANUS PRO
				CW
1200 (47)	262 (578)	546 (144,2)	6	AF - CS
				CR - CM - CS JANUS PRO
				CW
1300 (51)	280 (617)	602 (159,0)	6	AF - CS
				CR - CM - CS JANUS PRO
				CW

* weight of the tank excluding attachment

SC85 MIDI MACHINE WEIGHT 12,0 - 14,0 t (26455 - 30865 lb)

ADAPTERS	CS100 KG 45 (LB 99)	CS100 JANUS PRO KG 93 (LB 205)	CM180 KG 66 (LB 145)	CW20 KG 57 (LB 126)
----------	------------------------	-----------------------------------	-------------------------	------------------------

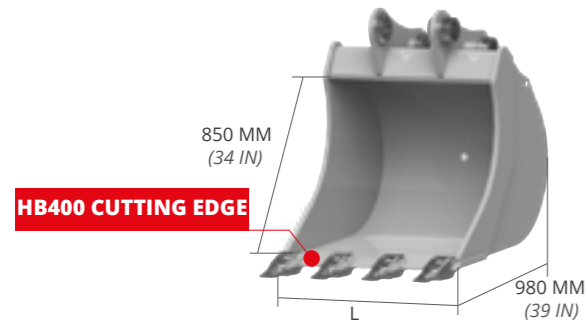

L MM (IN)	WEIGHT KG* (LB*)	CAP. SAE L (GAL)	TEETH N.	ADAPTERS
400 (16)	170 (375)	171 (45,2)	3	AF - CM
				CS - CW
				CS JANUS PRO
500 (20)	190 (419)	235 (62,1)	3	AF - CM
				CS - CW
				CS JANUS PRO
600 (24)	210 (463)	300 (79,3)	4	AF - CM
				CS - CW
				CS JANUS PRO
700 (28)	230 (507)	368 (97,2)	4	AF - CM
				CS - CW
				CS JANUS PRO
800 (31)	250 (551)	438 (115,7)	5	AF - CM
				CS - CW
				CS JANUS PRO
900 (35)	270 (595)	510 (134,7)	5	AF - CM
				CS - CW
				CS JANUS PRO
1000 (39)	291 (642)	584 (154,3)	5	AF - CM
				CS - CW
				CS JANUS PRO
1100 (43)	312 (688)	657 (173,6)	5	AF - CM
				CS - CW
				CS JANUS PRO
1200 (47)	333 (734)	730 (192,8)	6	AF - CM
				CS - CW
				CS JANUS PRO
1300 (51)	354 (780)	810 (214,0)	6	AF - CM
				CS - CW
				CS JANUS PRO

* weight of the tank excluding attachment

SC92 GD EXCAVATOR MACHINE WEIGHT 12,0 - 14,0 t (26455 - 30865 lb)

ADAPTERS	CS100 KG 45 (LB 99)	CS100 JANUS PRO KG 93 (LB 205)	CM180 KG 66 (LB 145)	CW20 KG 54 (LB 126)
----------	------------------------	-----------------------------------	-------------------------	------------------------

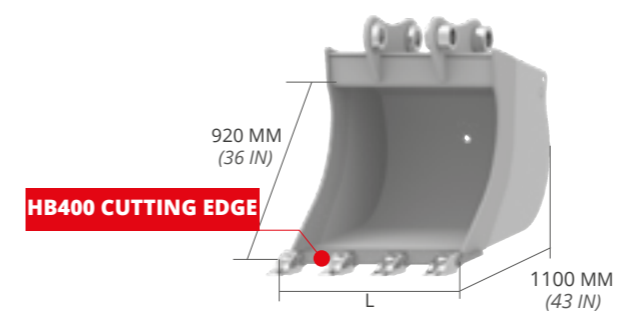

L MM (IN)	WEIGHT KG* (LB*)	CAP. SAE L (GAL)	TEETH N.	ADAPTERS
400 (16)			3	AF - CM
				CS - CW
				CS JANUS PRO
500 (20)			3	AF - CM
				CS - CW
				CS JANUS PRO
600 (24)	228 (503)	380 (100,4)	4	AF - CM
				CS - CW
				CS JANUS PRO
700 (28)	251 (553)	450 (118,9)	4	AF - CM
				CS - CW
				CS JANUS PRO
800 (31)	281 (619)	560 (147,9)	5	AF - CM
				CS - CW
				CS JANUS PRO
900 (35)	309 (681)	620 (163,8)	5	AF - CM
				CS - CW
				CS JANUS PRO
1000 (39)	350 (772)	700 (184,9)	5	AF - CM
				CS - CW
				CS JANUS PRO
1200 (47)	403 (888)	900 (237,7)	6	AF - CM
				CS - CW
				CS JANUS PRO

* weight of the tank excluding attachment

OPTIONAL

3	4
SUPPLEMENTARY BLADE	HB500 WELDED ADDITIONAL CUTTING EDGE

OPTIONAL

3	4
SUPPLEMENTARY BLADE	HB500 WELDED ADDITIONAL CUTTING EDGE

SC100 GD MACHINE WEIGHT 14,0 - 18,0 t (30865 - 39683 lb)

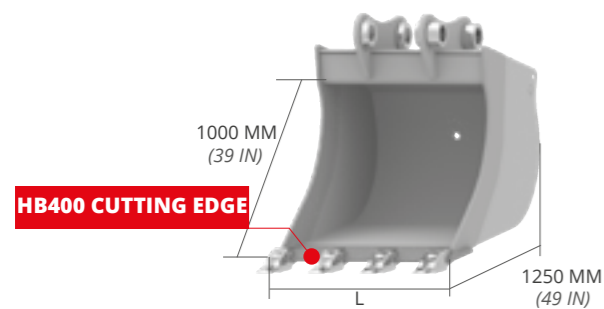
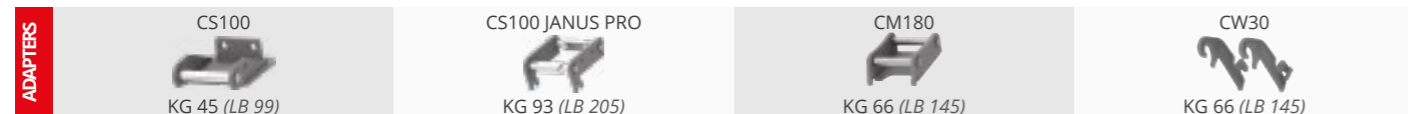

L MM (IN)	WEIGHT KG* (LB*)	CAP. L SAE (GAL)	TEETH N.	ADAPTERS
400 (16)				AF - CM CS - CW CS JANUS PRO
500 (20)				AF - CM CS - CW CS JANUS PRO
600 (24)	316 (697)	450 (118,9)	3	AF - CM CS - CW CS JANUS PRO
700 (28)	355 (783)	535 (141,3)	4	AF - CM CS - CW CS JANUS PRO
800 (31)	394 (869)	620 (163,7)	4	AF - CM CS - CW CS JANUS PRO
900 (35)	433 (955)	710 (187,5)	4	AF - CM CS - CW CS JANUS PRO
1000 (39)	472 (1041)	800 (211,3)	5	AF - CM CS - CW CS JANUS PRO
1200 (47)	550 (1213)	980 (258,8)	5	AF - CM CS - CW CS JANUS PRO

* weight of the tank excluding attachment

SC110 GD MACHINE WEIGHT 18,0 - 22,0 t (39683 - 48502 lb)

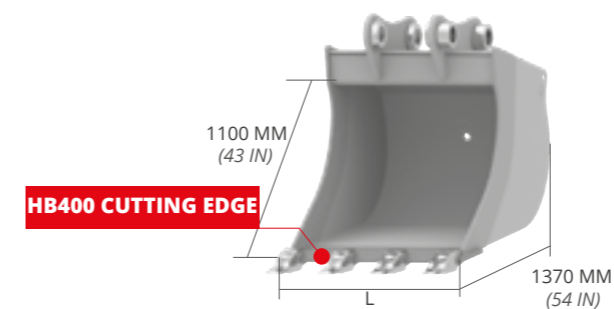
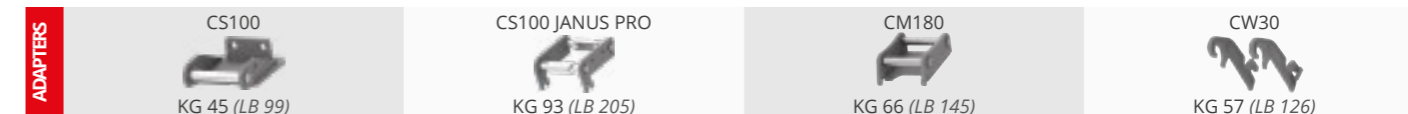

L MM (IN)	WEIGHT KG* (LB*)	CAP. L SAE (GAL)	TEETH N.	ADAPTERS
600 (24)	412 (908)	480 (126,8)	3	AF - CM CS - CW CS JANUS PRO
800 (31)	502 (1107)	690 (182,3)	4	AF - CM CS - CW CS JANUS PRO
1000 (39)	592 (1305)	900 (237,7)	5	AF - CM CS - CW CS JANUS PRO
1200 (47)	682 (1504)	1110 (293,2)	5	AF - CM CS - CW CS JANUS PRO
1300 (52)	727 (1603)	1220 (322,2)	6	AF - CM CS - CW CS JANUS PRO
1400 (55)	772 (1702)	1330 (351,3)	6	AF - CM CS - CW CS JANUS PRO

* weight of the tank excluding attachment

OPTIONAL

3	4
SUPPLEMENTARY BLADE	HB500 WELDED ADDITIONAL CUTTING EDGE

OPTIONAL

3	4
SUPPLEMENTARY BLADE	HB500 WELDED ADDITIONAL CUTTING EDGE